



### Application

- Can be used to transfer clean water or other liquids similar to water in physical and chemical properties
- Suitable for lifting water from the well, sprinkling irrigation in garden, pressure boosting of running water, and supporting equipment etc.

### Pump

- Cast iron pump body and support under special anti-rust treatment
- Stainless steel impeller
- AISI 304 shaft
- Max. liquid temperature: +60°C
- Max. suction: +9 m

### Motor

- Low noise&Long life bearing
- Motor with copper winding
- Built-in thermal protector for single phase motor
- Insulation class: F
- Protection class: IPX4
- Max. ambient temperature: +40°C

### Identification Codes

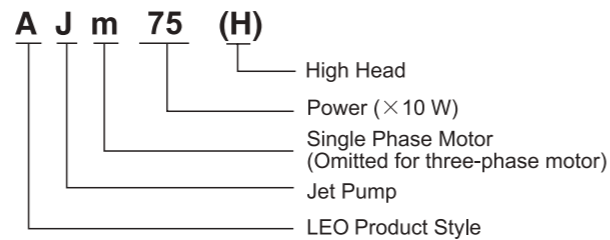

### Technical Data

MODEL	POWER		Q (m³/h)	Q (l/min)															
	kW	HP		0	0.3	0.6	0.9	1.2	1.5	1.8	2.1	2.4	2.8	3.0	3.3	3.6	3.9		
AJm30	0.3	0.4	H (m)	35	30	26	22.5	20	18	16	14	-	-	-	-	-	-		
AJm45	0.45	0.6		41	36	32	28	25	22	20	18	-	-	-	-	-	-		
AJm60	0.6	0.8		45	41	37	33.5	31	28.5	26	24	22.5	21	-	-	-	-		
AJm75	0.75	1.0		40	38	36	34.5	33	31.5	30	29	28	27	26	25	24	23		
AJm75H	0.75	1.0		51	47	43	40	37	34.5	32	30	27.5	25	-	-	-	-		
AJm90	0.9	1.2		48	46	44	42.5	41	39.5	38	36	35	34	33	32	31	30		
AJm90H	0.9	1.2		62	57	53	49	46	43	40	37	35	33	-	-	-	-		

### Hydraulic Performance Curves

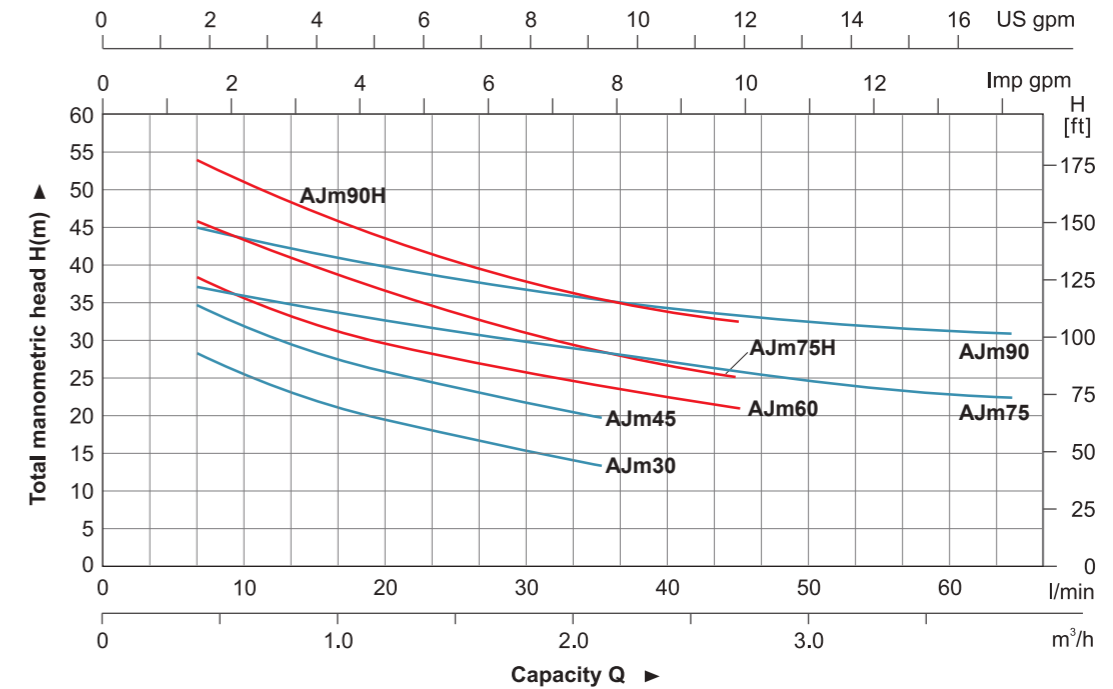

### Materials Table

No.	Part	Material
1	Pump body	HT 200
2	Venturi tube	PPO
3	Diffuser	PPO
4	Impeller	AISI 304
5	Mechanical seal	Carbon/Ceramic
6	O-ring	NBR
7	Support cover	AISI 304
8	Support	ZL 102
9	Bearing	
10	Rotor	
11	Fan cover	PP
12	Fan	PP
13	Rear cover	ZL 102
14	Capacitor	
15	Terminal box	PA6-GF25
16	Terminal board	
17	Stator	

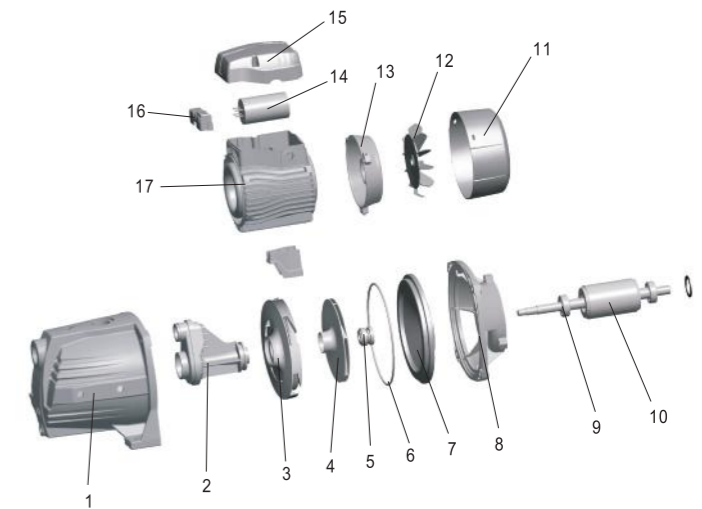

### Package Information

Model	GW (Kgs)	L (mm)	W (mm)	H (mm)	Quantity (PCS/20' TEU)
AJm30	9.2	390	185	215	1740
AJm45	10.15	390	185	215	1740
AJm60	14.35	455	215	245	1170
AJm75	15.5	455	215	245	1170
AJm75H	15.5	450	215	245	1170
AJm90	16.45	455	215	245	1170
AJm90H	16.45	450	215	245	1170



### Dimension

Model	DN1	DN2	A (mm)	B (mm)	C (mm)	D (mm)	E (mm)	F (mm)	G (mm)
AJm30	1"	1"	358	160	105	180	89.5	90	10
AJm45			358	160	105	180	89.5	90	10
AJm60			418	190	150	212	113	100	10
AJm75			418	190	150	212	113	100	10
AJm75H			418	190	150	212	113	100	10
AJm90			418	190	150	212	113	100	10
AJm90H			418	190	150	212	113	100	10

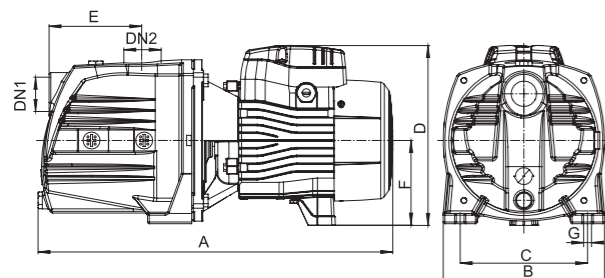



### Application

- Can be used to transfer clean water or other liquids similar to water in physical and chemical properties
- Suitable for lifting water from the well, sprinkling irrigation in garden, pressure boosting of running water, and supporting equipment etc.

### Pump

- Cast iron pump body and support under special anti-rust treatment
- Stainless steel impeller
- AISI 304 shaft
- Max. liquid temperature: +60°C
- Max. suction: +9 m

### Motor

- Low noise&Long life bearing
- Motor with copper winding
- Built-in thermal protector for single phase motor
- Insulation class: F
- Protection class: IPX4
- Max. ambient temperature: +40°C

### Identification Codes

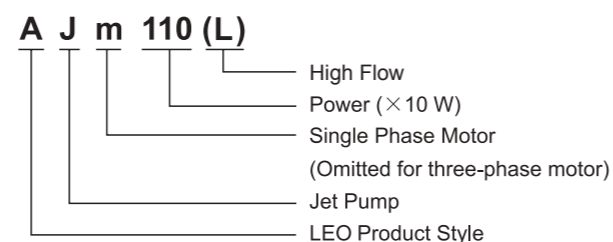

### Technical Data

MODEL	POWER		Q (m³/h)																
	kW	HP	0	0.6	0.9	1.2	1.5	1.8	2.1	2.4	2.7	3.0	3.6	4.2	4.8	6.0	7.2	8.4	
AJm110H	1.1	1.5	56	50	46	44	42	40	38	36	34	32	30	28	-	-	-	-	
AJm150H	1.5	2	71	65	61	59	57	54	51	48	45	43	39	34	-	-	-	-	
AJ(m)220H	2.2	3	86	78	75	71	68	65	63	60	57.5	55	51.5	46	-	-	-	-	
AJm110	1.1	1.5	55	52	49	48	46	45	43	42	41	40	37	35	33	27	-	-	
AJm150	1.5	2	60	56	55	53	52	49	48	46	45	44	42	40	36	33	-	-	
AJ220	2.2	3	72	70	68	66	65	63	61	59	57	56	54	51	48	44	-	-	
AJm110L	1.1	1.5	48	45	44	43	42	41	40	39	38	36	34	32	30	24	17	9	
AJm150L	1.5	2	55	53	52	51	49	48	46	45	44	43	42	39	38	34	31	26	
AJ220L	2.2	3	55	53	52	42	51.5	51	50.5	49.5	49	48	47	45	44	41	38	36	

### Dimension

Model	DN1	DN2	L (mm)	W (mm)	H (mm)	L <sub>i</sub> (mm)	W <sub>i</sub> (mm)	H <sub>i</sub> (mm)
AJm110	1 1/4"	1"	512	206	236	153	178	112
AJm110H			512	206	236	153	178	112
AJm110L			512	206	236	153	178	112
AJm150			512	206	236	153	178	112
AJm150H			512	206	236	153	178	112
AJm150L			512	206	236	153	178	112
AJ220	1 1/2"	1 1/2"	512	206	236	153	178	112
AJ(m)220H			512	206	236	153	178	112
AJ220L			512	206	236	153	178	112

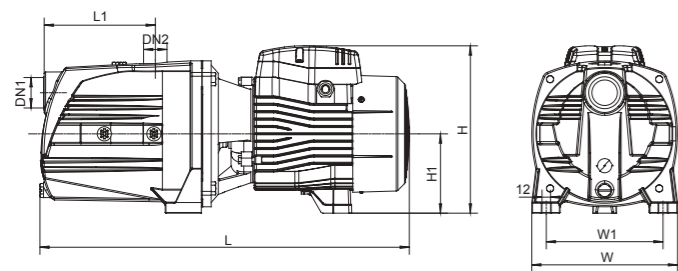

### Hydraulic Performance Curves

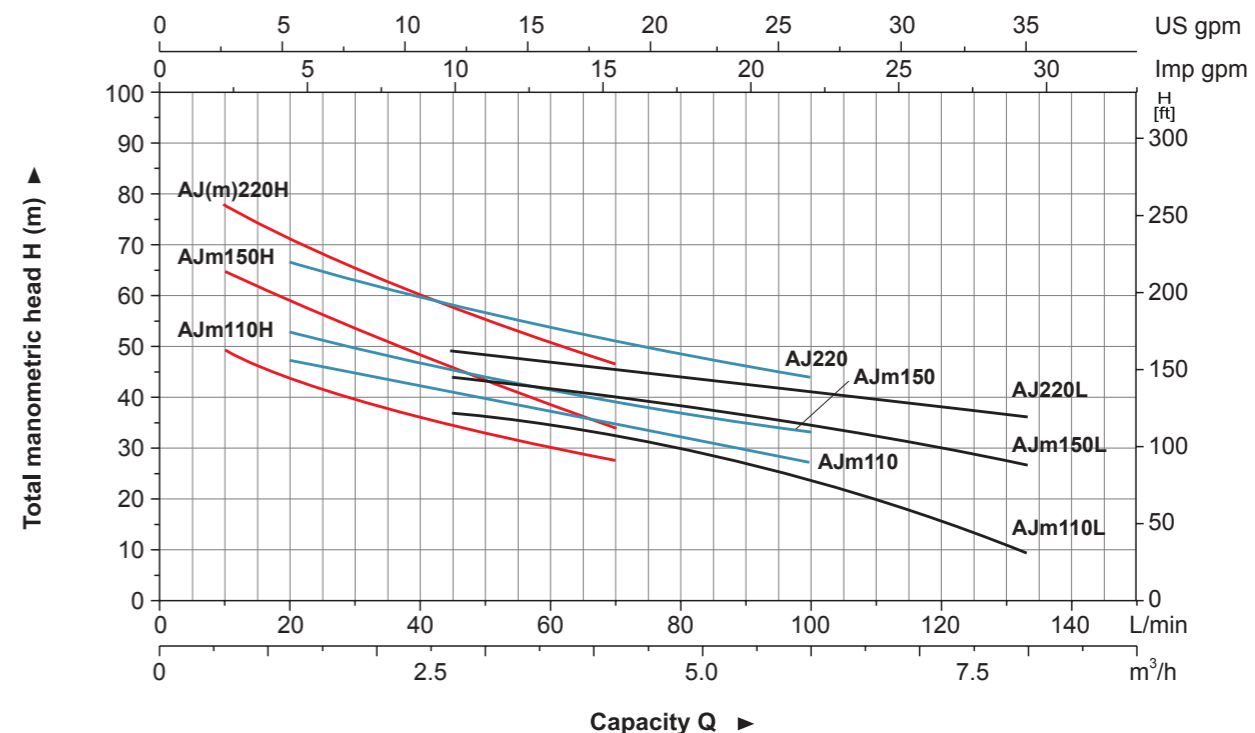

### Materials Table

No.	Part	Material
1	Pump body	HT200
2	Nozzle	PPO
3	O-ring	NBR
4	Venturi tube	PPO
5	Diffuser	PPO
6	Mechanical seal	Carbon/Ceramic
7	Impeller	AISI 304
8	Support cover	HT200
9	Support	ZL102
10	Bearing	
11	Rotor	
12	Stator	
13	Terminal board	PC
14	Terminal box	PA6-GF25
15	Capacitor	
16	Rear cover	ZL102
17	Fan	PP
18	Fan cover	PP

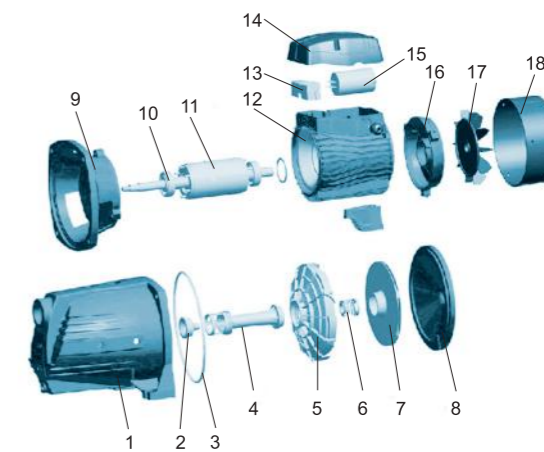

### Package Information

Model	GW (Kgs)	L (mm)	W (mm)	H (mm)	Quantity (PCS/20' TEU)
AJm110	24.5	572	225	259	816
AJm110H	24.5	572	225	259	816
AJm110L	24.5	572	225	259	816
AJm150	25.4	572	225	259	816
AJm150H	25.4	572	225	259	816
AJm150L	25.4	572	225	259	816
AJ(m)220H	26.0	572	225	259	816

