



DC 160-310



DCT 410-1000



DCT 410-1000/P



Pompe da drenaggio con girante centrifuga che garantisce una elevata prevalenza; adatte ad applicazioni civili e industriali; sono state particolarmente progettate per uso estremamente gravoso; sono disponibili solo per applicazione mobile.

Centrifugal drainage pump that guarantees high head; ideal for civil and industrial applications; specifically designed for very heavy use; only mobile versions are available.

Bombas de drenaje con rodete centrífugo que garantiza una elevada prevalencia; apropiadas para aplicaciones civiles e industriales; se han proyectado especialmente para un uso extremadamente gravoso; están disponibles sólo para aplicación móvil.

Pompes de drainage avec une roue centrifuge qui garantit une hauteur manométrique élevée; indiquées pour les applications civiles et industrielles; elles ont été spécialement conçues pour un service très intense; disponibles uniquement pour applications mobiles.

**CARATTERISTICHE COSTRUTTIVE / CONSTRUCTION FEATURES  
CARACTERÍSTICAS CONSTRUCTIVAS / CARACTÉRISTIQUES D'EXÉCUTION**

<b>Corpo pompa Pump body Cuerpo bomba Corps de pompe</b>	ghisa cast iron fundición fonte
<b>Girante Impeller Rodete Turbine</b>	ghisa cast iron fundición fonte
<b>Tenuta meccanica Mechanical seal Sello mecánico Garniture mécanique</b>	doppia tenuta con barriera d'olio: carburo di silicio lato pompa, ceramica-grafite lato motore double seal with oil barrier: silicon carbide on pump side, ceramic-graphite on motor side doble sello con cámara interpuesta: carburo de silicio lado bomba, cerámica-grafito lado motor double garniture avec film lubrifiant: carbure de silice côté pompe, céramique-graphite côté moteur
<b>Albero motore Motor shaft Eje motor Arbre moteur</b>	acciaio AISI 304 stainless steel AISI 304 acero AISI 304 acier AISI 304
<b>Passaggio corpi solidi Passage of solids Pajo de solidos Passage corps solides</b>	10 mm
<b>Profondità di immersione Depth of immersion Profundidad inmersión Profondeur immersion</b>	max 20 m
<b>Temperatura del liquido Liquid temperature Temperatura del liquido Température du liquide</b>	0 - 40 °C
<b>Cavo Cable Cable Câble</b>	H07 RNF, 10 m
<b>Viteria Bolts Tornillos Vis</b>	acciaio inossidabile A2 A2 stainless steel acero A2 acier A2
<b>Base appoggio Foot support Placa base Plaque de base</b>	ferro zincato galvanized iron hierro galvanizado fer galvanisé
<b>Guarnizioni Gaskets Anilos Joints</b>	gomma NBR NBR rubber goma NBR caoutchouc NBR
<b>MOTORE / MOTOR / MOTOR / MOTEUR</b>	
<b>Motore 2 poli a induzione in bagno d'olio</b>	3~ 230/400V-50Hz 1~ 230V-50Hz necessario condensatore d'avviamento (35µF per modello da 1,5HP, 50µF per modello da 2HP)
<b>2 pole induction motor in oil bath</b>	required starter capacitor (35µF for 1,5HP model, 50µF for 2HP model)
<b>Motor de 2 polos a inducción en baño de caeite</b>	necesario condensador de arranque (35µF para modelo 1,5HP, 50µF para modelo 2HP)
<b>Moteur à induction à 2 pôles en bain d'huile</b>	nécessaires condensateur de démarrage (35µF pour modèle 1,5HP, 50µF pour modèle 2HP)
<b>Classe di isolamento Insulation class Clase de aislamiento Clase d'isolation</b>	F
<b>Grado di protezione Protection degree Grado de protección Protection</b>	IP68

Q [imp g.p.m.]  
Q [US g.p.m.]

H [m]  
H [ft]

Q [m<sup>3</sup>/h]  
Q [l/min]

HP  
Q [m<sup>3</sup>/h]

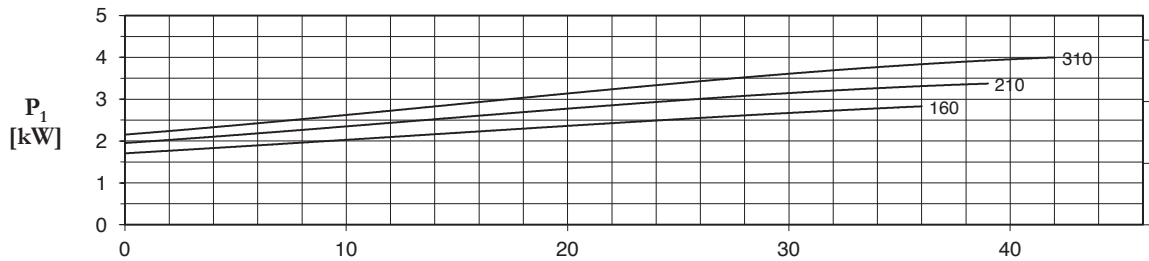
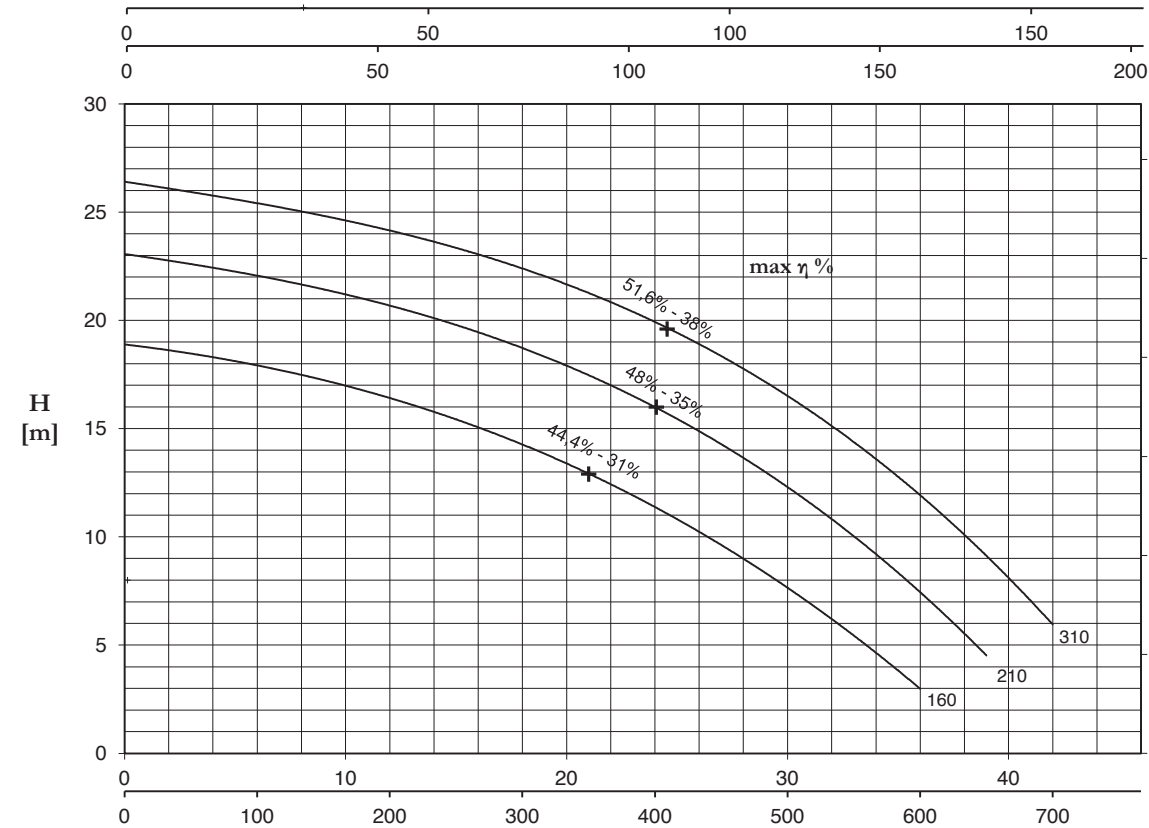

TYPE		AMPERE				
1~	3~	230 V 50 Hz	3x230 V 50 Hz (*)	3x400 V 50 Hz	230/400 V 50 Hz $\lambda / \Delta$ (*)	400/690 V 50 Hz $\lambda / \Delta$
DC 160	DCT 160	13,8	8,3	4,8	-	-
DC 210	DCT 210	16,5	10,2	5,9	-	-
-	DCT 310	-	12,0	6,9	-	-

+ max  $\eta$  %

max rendimento idraulico e rispettivo rendimento totale  
max hydraulic efficiency and respective total efficiency  
máx rendimiento hidráulico y correspondiente rendimiento total  
max rendement hydraulique et rendement total

(\*) no standard execution

TYPE		P2		P1 (kW)		Q (m <sup>3</sup> /h - l/min)									
1~	3~	P2		P1 (kW)		0	6	12	18	24	30	36	39	42	
		(HP)	(kW)	1~	3~	0	100	200	300	400	500	600	650	700	
						H (m)									
DC 160	DCT 160	1,5	1,1	3,0	2,8	18,9	17,9	16,4	14,3	11,4	7,6	3,0	-	-	
DC 210	DCT 210	2	1,5	3,7	3,4	23,0	22,2	20,7	18,6	15,9	12,5	7,4	4,5	-	
-	DCT 310	3	2,2	-	4,0	26,4	25,4	24,2	22,4	19,9	16,4	12,1	9,1	5,9	

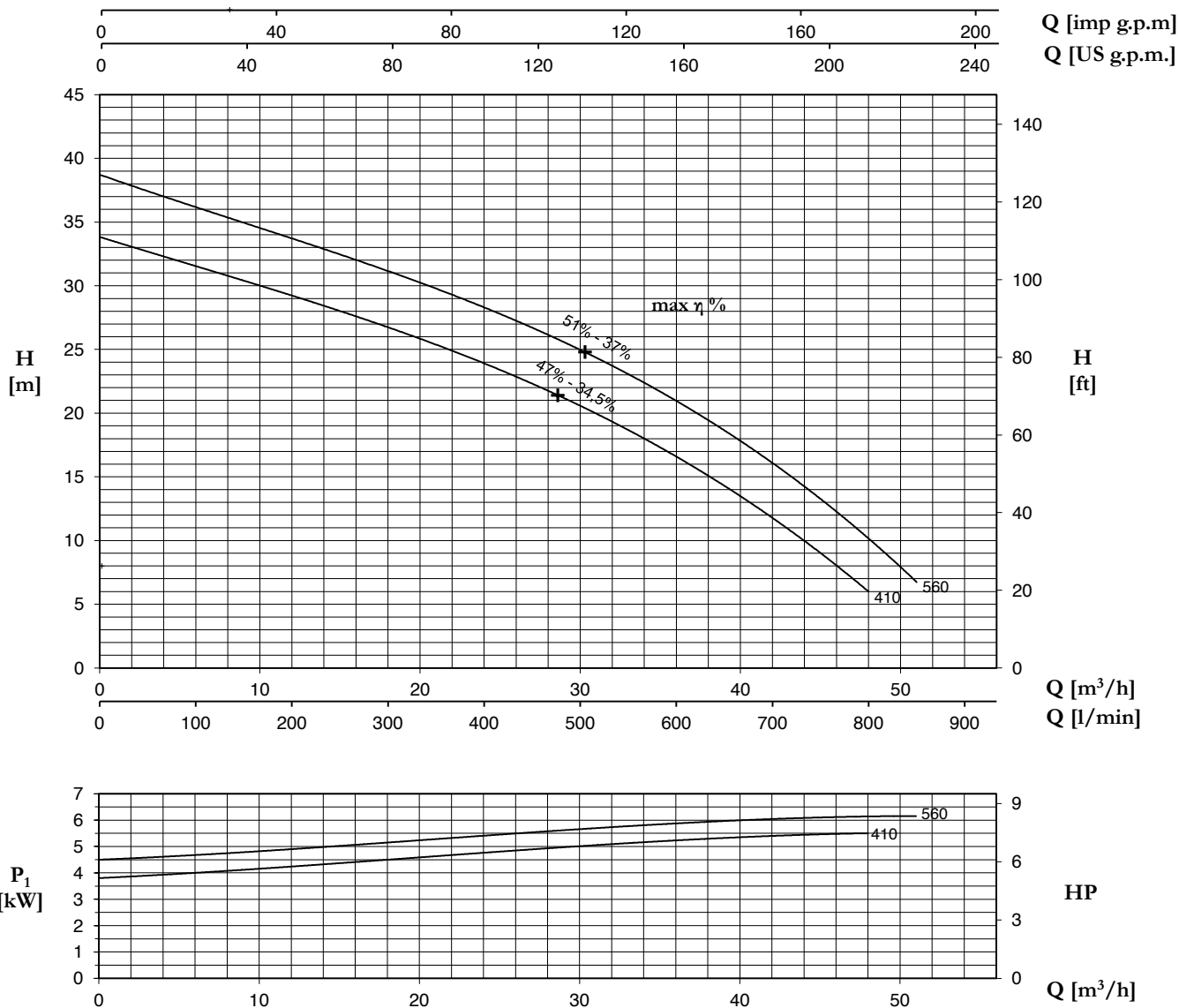

TYPE	AMPERE			
	3x230 V 50 Hz (*)	3x400 V 50 Hz	230/400 V 50 Hz λ / Δ (*)	400/690 V 50 Hz λ / Δ
DCT 410	15,4	8,9	-	-
DCT 560	18,5	10,7	-	-

(\*) no standard execution

+ max η %

max rendimento idraulico e rispettivo rendimento totale  
max hydraulic efficiency and respective total efficiency  
máx rendimiento hidráulico y correspondiente rendimiento total  
max rendement hydraulique et rendement total

TYPE	P2		P1 (kW)	Q (m³/h - l/min)										
				0	6	12	18	24	30	36	42	48	51	
				0	100	200	300	400	500	600	700	800	850	
	(HP)	(kW)	3~	H (m)										
DCT 410	4	3	5,5	33,8	31,6	29,2	26,8	23,9	20,5	16,5	12,0	5,9	-	
DCT 560	5,5	4	6,3	38,7	36,1	33,9	31,2	28,3	24,7	20,9	16,3	10,4	6,5	

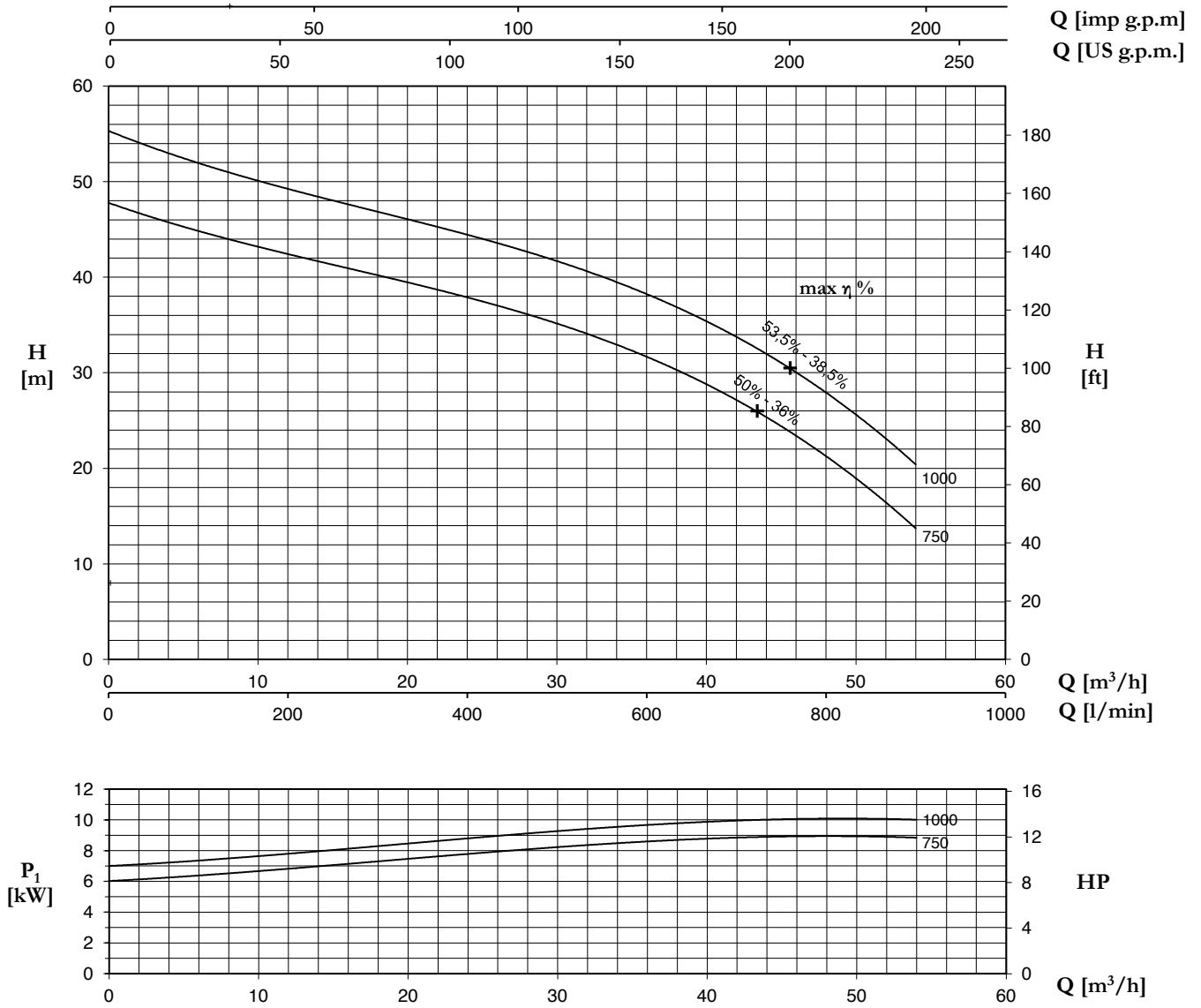

TYPE	AMPERE			
	3x230 V 50 Hz (*)	3x400 V 50 Hz	230/400 V 50 Hz λ / Δ (*)	400/690 V 50 Hz λ / Δ
DCT 750	-	15,3	26,5	15,3
DCT 1000	-	17,5	30,3	17,5

(\*) no standard execution

+ max η %

max rendimento idraulico e rispettivo rendimento totale  
 max hydraulic efficiency and respective total efficiency  
 máx rendimiento hidráulico y correspondiente rendimiento total  
 max rendement hydraulique et rendement total

TYPE	P2		P1 (kW)	Q (m³/h - l/min)									
				0	12	18	24	30	36	42	48	54	
				0	200	300	400	500	600	700	800	900	
	(HP)	(kW)	3~	H (m)									
DCT 750	7,5	5,5	9,0	47,6	42,9	40,4	37,7	34,7	31,2	27,4	22,3	13,1	
DCT 1000	10	7,5	10,3	55,1	49,8	47,1	44,2	41,1	37,8	34	29,1	19,7	

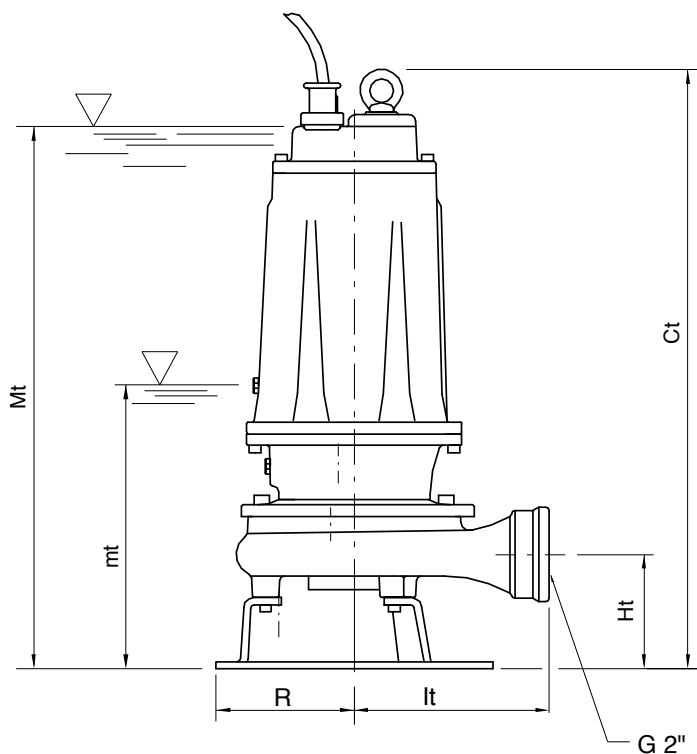

Mt: livello minimo di funzionamento continuo  
 Mt: lowest level for continuous duty  
 Mt: nivel minimo de funcionamiento continuo  
 Mt: niveau minimum de fonctionnement continu

mt: livello minimo di funzionamento  
 mt: lowest working level  
 mt: nivel minimo de funcionamiento  
 mt: niveau minimum de fonctionnement

TYPE	DIMENSIONS (mm)						DNm	Kg
	Ct	Ht	R	lt	mt	Mt		
DC 160 - DCT 160	513	102	117	174	205	475	2" G	35
DC 210 - DCT 210	513	102	117	174	205	475	2" G	36
DCT 310	513	102	117	174	205	475	2" G	37

TYPE	PROTECTION			CONTROL PANEL		
	1 x 230 V	3 x 400 V	400 / 690 V	1 x 230 V	3 x 400 V	400 / 690 V
DC 160	PMC 15/35-15	PT 20-30-40/4.3-6.8	-	QM 10-15/35/2-18	QT 10-40/2-8	-
DC 210	PMC 20/50-18	PT 20-30-40/4.3-6.8	-	QM 20/50/2-18	QT 10-40/2-8	-
DCT 310	-	PT 40-50/5.7-9.1	-	-	QT 10-40/2-8	-
DCT 410	-	PT 55-75/8.6-13.5	-	-	QT 55/2-11	-
DCT 560	-	PT 55-75/8.6-13.5	-	-	QT 75/2-16	-
DCT 750	-	PT 100/12.5-16.5	AV 75/7-10	-	QT 75/2-16	QAV 75/7-10
DCT-1000	-	PT 125-150/16-21	AV 100/9-12	-	QT 100-125/16-22	QAV 100/9-12

Mt/Mf: livello minimo di funzionamento continuo  
 Mt/Mf: lowest level for continuous duty  
 Mt/Mf: nivel minimo de funcionamiento continuo  
 Mt/Mf: niveau minimum de fonctionnement continuu

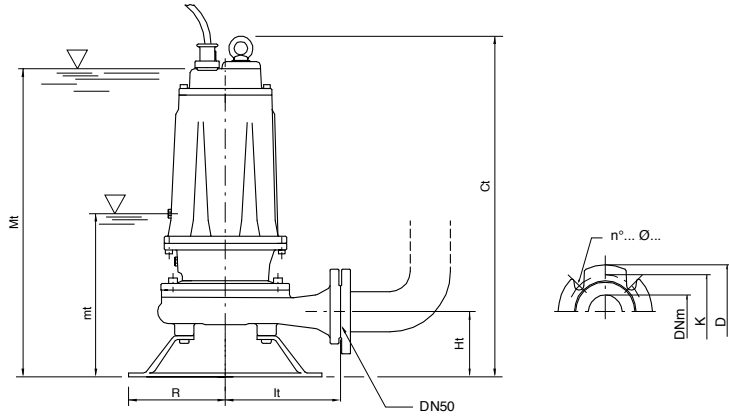

TYPE	DIMENSIONS (mm)							Kg
	Ct	Ht	R	lt	mt	Mt	DNm	
<b>DCT 410</b>	595	112	160	187	263	550	50	56
<b>DCT 560</b>	595	112	160	187	263	550	50	64
<b>DCT 750</b>	680	160	180	250	280	630	65	92
<b>DCT 1000</b>	680	160	180	250	280	630	65	96

mt/mf: livello minimo di funzionamento  
 mt/mf: lowest working level  
 mt/mf: nivel minimo de funcionamiento  
 mt/mf: niveau minimum de fonctionnement

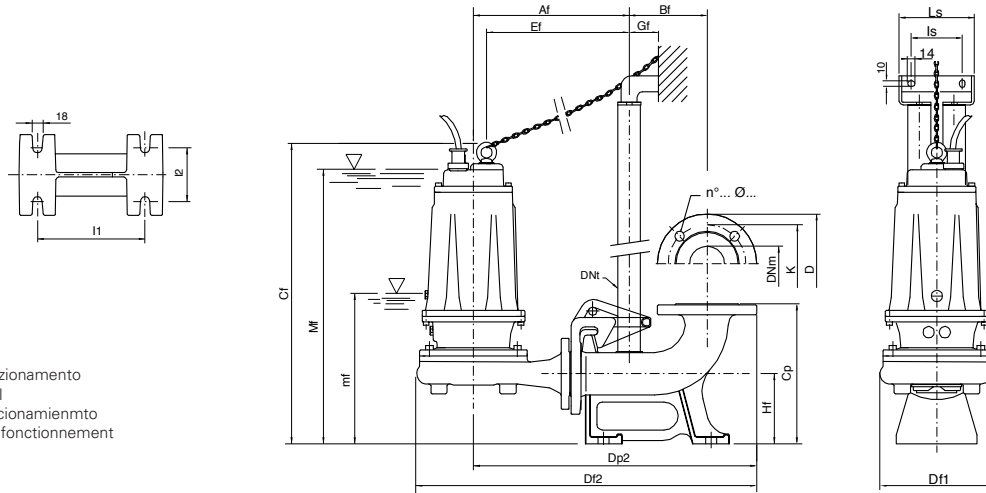

TYPE	DIMENSIONS (mm)																	
	Af	Bf	Cf	Cp	Df1	Df2	Dp2	DNt	Ef	Gf	Hf	l1	l2	ls	Ls	mf	Mf	DNm
<b>DCT 410/P</b>	300	145	614	260	237	654	535	1" 1/4	269	55	130	200	100	95	140	290	566	50
<b>DCT 560/P</b>	300	145	614	260	237	654	535	1" 1/4	269	55	130	200	100	95	140	290	566	50
<b>DCT 750/P</b>	331	145	656	260	279	701	569	1" 1/4	296	55	130	200	100	95	140	290	600	65
<b>DCT 1000/P</b>	331	145	656	260	279	701	569	1" 1/4	296	55	130	300	100	95	140	290	600	65

Flange UNI PN 10 (mm)			
DNm	K	D	n°... Ø...
50	125	165	4... 18...
65	145	185	4... 18...

TYPE	TRUCK		CONTAINER	
	PALLET (cm)	N° pumps	PALLET (cm)	N° pumps
<b>DC 160-310</b>	85X110X145	18	85X110X190	27
<b>DCT 410-560</b>	85X110X170	12	85X110X170	12
<b>DCT 750-1000</b>	100X120X190	12	100X120X190	12

